

Temporary Horizontal Lifelines

HL3 Series



HL3-IA
Pass Through Adapter



Technical Information on Back



HL3-60 Shown

HL3-IS Shown

GEMTOR[™]

...when your life is on the line[™]

One Johnson Avenue
Matawan, NJ 07747
Phone: 800-405-9048
Fax: 732-290-9391
Email: sales.info@gemtor.com
www.gemtor.com

Temporary Horizontal Lifelines

Gemtor's single/multi span horizontal lifeline system is the perfect choice for worker safety during bridge and building construction. Designed for quick and easy mounting to structural I-Beams, this complete kit includes everything you need to protect your workers while performing their tasks at heights. Each two (2) stanchion system can be used on a span of up to 60 feet. Intermediate stanchions and Add-On systems can be deployed to create a system of unlimited length.

Large mounting bolts that provide more surface area contact, are located on the top side of the stanchion basing attachment to a beam safer and easier than competitive systems. The stanchions feature an adjustable U shaped clamp and safety chain system that wraps around the opposite top flange of the beam providing additional security. The chain is attached to a bolt that has a long handled nut for ease of tightening.

When the installation is complete, the provided tethered stainless steel pins are used to secure the position of the safety chain as it passes through the two (2) guides located on the stanchion and the clamp. The stanchions are extremely strong yet lightweight. They attach to the beam in a manner that minimally impacts the space required for the body of a worker to pass by.

Features

- ☑ Fits beams of up to 3" thick and 36" wide.
- ☑ Unique design angles stanchion away from the worker allowing more room.
- ☑ Spans of up to 60 feet between two (2) stanchions.
- ☑ For use as fall protection and/or a hand rail by up to two (2) workers.
- ☑ Attaches with top mounted bolts, plated chain and quick insert pins.
- ☑ No drilling or welding required.
- ☑ Compact and lightweight (stanchions weigh 35 pounds each).
- ☑ Reusable*.

* System shall be inspected before and after each use by a qualified person. In the event of a fall, the energy absorber, cable and lifeline hardware must be replaced.

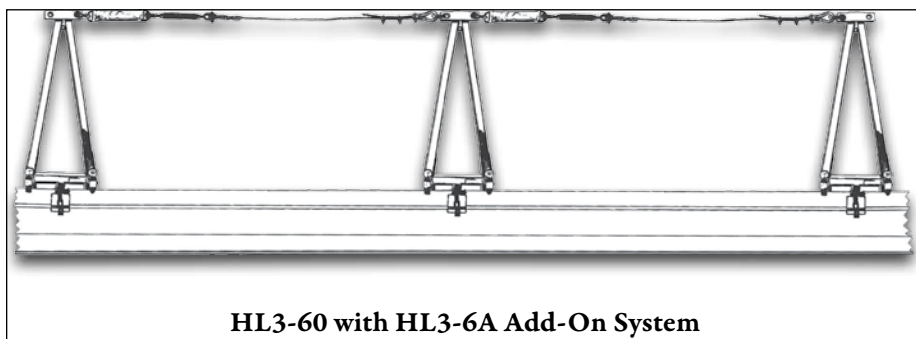
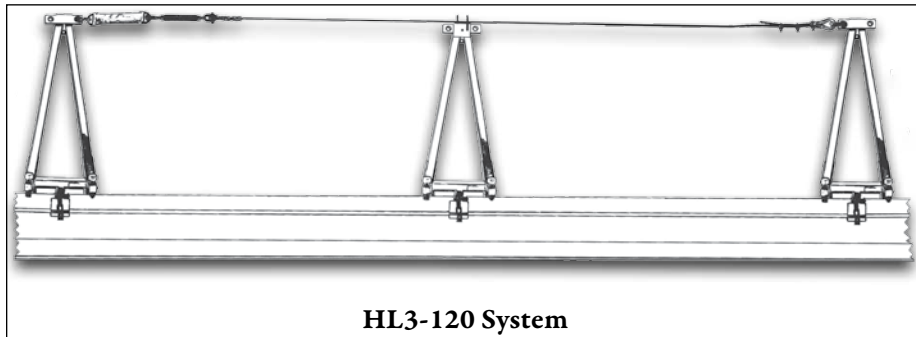

Complete Systems

HL3-30 – Portable Horizontal Lifeline System for up to 30 ft. span. Includes; two (2) stanchions, energy absorber, cable and hardware.

HL3-60 – Portable Horizontal Lifeline System for up to 60 ft. span. Includes; two (2) stanchions, energy absorber, cable and hardware.

HL3-120 – Multi-span Portable Horizontal Lifeline System for up to 120 ft. span. Includes; two (2) end stanchions, one (1) passable intermediate stanchion, energy absorber, cable and hardware.

HL3-180 – Multi-span Portable Horizontal Lifeline System for up to 180 ft. span. Includes; two (2) end stanchions, two (2) passable intermediate stanchions, energy absorber, cable and hardware.

Add-On Systems

HL3-3A – Portable Horizontal Lifeline Add-on System for up to 30 ft. span. Includes; one (1) stanchion, energy absorber, cable and hardware.

HL3-6A – Portable Horizontal Lifeline Add-on System for up to 60 ft. span. Includes; one (1) stanchion, energy absorber, cable and hardware.

HL3-12A – Portable Horizontal Lifeline Add-on System for up to 120 ft. span. Includes; one (1) stanchion, one (1) intermediate stanchion, energy absorber, cable and hardware.

HL3-18A – Portable Horizontal Lifeline Add-on System for up to 180 ft. span. Includes; one (1) stanchion, two (2) intermediate stanchions, energy absorber, cable and hardware.

Components & Replacement Parts

HL3-S1 – Additional stanchion for portable horizontal lifeline system

HL3-IA – Bolt-on, passable intermediate adapter for use with HL3-S1

HL3-IS - Intermediate stanchion converts single-span system to multi-span system or allows multi-span system to be expanded up to 180 ft. total length.

HL3-EA – Replacement Energy absorber

HL-628-30 – Replacement galvanized steel cable lifeline and hardware for HL3-30

HL-628-60 – Replacement galvanized steel cable lifeline and hardware for HL3-60

HL-628-120 – Replacement galvanized steel cable lifeline and hardware for HL3-120

HL-628-180 – Replacement galvanized steel cable lifeline and hardware for HL3-180

Your Authorized Gemtor Distributor:



GEMTOR[™]

... when your life is on the line[™]

Gemtor, Inc. • 1 Johnson Avenue • Matawan, NJ 07747

Phone: 800-405-9048 • Fax: 732-290-9391

www.gemtor.com

HL3/IS_02-2012