



GEMTOR, INC.

...when your life is on the line

One Johnson Avenue \$ Matawan, NJ 07747

732-583-6200 \$ 800-405-9048 \$ Fax 732-290-9391

OWNER'S MANUAL

**Installation, Operating, Inspection and Maintenance Instructions
Gemtor Temporary Horizontal Lifeline System with Unitensioner[®]**

Model # HL1-60 – Complete Synthetic Rope Horizontal Lifeline System



⚠ Warning

You must read and fully understand all instructions, or have all instructions explained to you, before attempting to use this device. Equipment must not be installed, operated or inspected by anyone who does not understand this Owner's Manual. Failure to observe these instructions could result in serious injury or death. Careless or improper use of this equipment can result in serious injury or death. Training and instruction review should be repeated at regular intervals. If you have any questions regarding these instructions or need additional copies, call Gemtor toll free at 800-405-9048.

**IMPORTANT: THESE INSTRUCTIONS SHOULD BE KEPT
WITH THE DEVICE AT ALL TIMES.**

IMPORTANT INFORMATION:

Purchased from (Distributor): _____

Address: _____

City: _____ **State** _____ **Zip** _____

Purchase Date: _____

Model Number: _____

Serial Number: _____

Property of:

Keep this information for future reference.

IMPORTANT: Return registration card immediately

IMPORTANT OSHA INFO (subpart M - 1926.502(d)(8))

Horizontal lifelines shall be designed, installed and used under the supervision of a qualified person, as part of a complete personal fall arrest system, which maintains a safety factor of at least two.

⚠ IMPORTANT

When using any lifeline, regardless of configuration or manufacture, it is important to realize that there are some definite limitations on use that must be considered, and definite work practices that must be followed. Lifelines are flexible anchorages that allow a worker to be tied-off at any point along either a vertical or horizontal span. Unlike a fixed anchorage, lifelines are susceptible to substantial movement, elongation and deflection when subjected to the forces of a fall. These inherent characteristics of a lifeline must be considered when a worker is planning his fall protection system to ensure that he cannot strike a lower level or be otherwise injured.

When more than one worker shares a lifeline* extreme care must be taken to ensure that if one worker falls, lifeline movement, elongation and deflection do not adversely affect the other workers. Specifically, a qualified/competent person must ensure that the system is rigged and the workers are positioned in such a manner so that if one worker falls, it would not cause one or more other workers to fall. To reduce the possibility of serious injury, if more than one worker is within the same segment of a multiple man horizontal lifeline system, the system must be rigged so that lanyard length is greater than potential lifeline deflection and potential free fall distance is minimized.

***Note:** OSHA does not allow more than one worker on a vertical lifeline. Gemtor recommends that only one worker be tied-off between supports on any lifeline.

GENERAL DESCRIPTION

The Gemtor Model # HL1-60 Horizontal Rope Lifeline Systems are designed for use as a temporary, horizontal, fixed safety and grab line that can support the fall of a worker attached to the system. They are used in high places such as transmission towers, shipyards, buildings, bridges, and dams, as well as on construction sites.

The Horizontal lifeline must be suspended between two approved anchor points. When a worker, who is wearing an approved full-body harness with a lanyard, attaches himself to the Horizontal lifeline, he is able to move freely along the length of the lifeline to perform his tasks. In the event the worker loses his footing, or otherwise falls, the horizontal lifeline, in combination with the lanyard and harness, will arrest the fall and reduce the possibility of serious injury.

In order to function properly, the horizontal lifeline must be sufficiently taut. Under proper tension, the HL1 lifeline allows the worker's lanyard to move easily along the lifeline.

In the event of a fall, a worker generates many times his weight in force which is exerted on all components of the fall arrest system including the lifeline and its anchorages. Accordingly, the lifeline, the anchorage and the structure to which the anchorage is fastened, are all susceptible to failing under the force. The HL1 is designed to substantially reduce these forces through deflection, elongation and friction. To safely compensate for deflection, lifeline elongation, the worker's height and lanyard length, the HL1 must be properly rigged at the correct height (see charts on page 6 & fig. 2 on, page 10).

The HL1's automatic tensioning device, Unitensioner[®], is the basic component of the system. The Unitensioner[®] significantly reduces the force of a fall as applied to both the falling worker and the lifeline anchor points.

APPLICATION

The Gemtor Horizontal Rope Lifeline System (HL1-60) is designed for use as a temporary, horizontal, fixed safety and hand grab line that can support the fall of a worker attached to the system. Its is used in high places such as transmission towers, shipyards, buildings, and dams, as well as on construction sites.

SYSTEM COMPONENTS

The Gemtor Horizontal Lifeline System consists of the following approved components.

- Unitensioner[®]
- 5/8" diameter low stretch synthetic rope
- Two (2) O-Rings
- Two (2) anchorage webbing slings
- Two (2) automatic locking carabiners
- Two (2) adjustable length web lanyards (not shown)
- Carrying/storage bag



It is acceptable to install the Gemtor Horizontal Rope Lifeline System directly to suitable anchorages using carabiners as an alternative to using the anchor slings supplied with the system.

The Gemtor HL1-60 Horizontal Rope Lifeline System is supplied completely assembled and ready for use.

The Gemtor HL1-60 is designed for use with Gemtor approved components. Substitution or replacement with non-approved components will endanger the system's integrity and may effect the reliability and safety of the total system.

Unitensioner[®] performs the following functions:

- Stretches the synthetic rope.
- Maintains the desired lifeline tension.
- Absorbs energy generated during a worker's fall.
- Makes adjustment of lifeline tension fast and easy, and eliminates over tightening.

Unitensioner[®] (fig. 4, page 11) consists of the following parts:

- Housing (1)
- Pulley (2)
- Axle (3) interconnected with the pulley (2) through two mechanisms, A & B.
- "A" mechanism maintains the force necessary for proper lifeline tension.
- "B" mechanism absorbs the energy of the fall.
- Orange push button (4) is for disengaging the shock absorber mechanism.
- Rope Grab (5)
- Lever (6)
- Ring (7)

Unitensioner[®] works in the following way:

The free end of the lifeline passes between two rollers (fig. 3), around the pulley (fig. 4), back between two rollers and through the safety ring (fig. 3, 4). The free end of the lifeline then passes through the rope grab. The lifeline must have a compensation loop (fig. 1, 3) between the safety ring and the rope grab (fig. 3). A knot* must be tied in the end of the lifeline after it is passed through the rope grab (fig. 3). When a worker makes the lifeline taut, by rotating the lever (fig. 4), and the tension of the lifeline reaches the desired force, the clicking will stop, and the lever will continue to rotate freely. **A worker cannot increase the tension.** In the event of a fall, the sudden increase in force on the lifeline will cause the pulley to rotate and the compensation loop to pass to the lifeline side of the Unitensioner[®]. An energy absorbing mechanism will absorb the energy of the fall and reduce the forces on the worker and the anchor points (fig. 5). When the system stops, the worker will be suspended by the lifeline. After rescue operations, the lifeline must be withdrawn from service and sent to Gemtor, Inc. for inspection of the system and rope replacement.

*The HL1 system is supplied with a back splice at the free end of the lifeline.

Synthetic Rope

- 5/8" Diameter High strength polypro rope. (Co-polymer, polypropylene and polyethylene) ID color of High strength polypro is green with one yellow tracer in each strand. **The high strength polypro rope supplied from Gemtor, Inc. is the only acceptable rope for this system. The use of any other rope may result in malfunction of the system and possible serious injury or death.**
- Tensile Strength = 10,000 lb.
- Two times stronger than regular polypropylene.
- Excellent UV resistance.
- Will not harden with age.
- Very good resistance to alkalis and acids.
- Less elongation and water absorption.
- Develops a feathered surface protecting it against abrasion.

Splices

Standard 3-tuck splice on one end with a steel thimble to protect the lifeline rope eye from wear. Other end of lifeline is back spliced. Strength of splice is equal to that of the rope. The ends of the rope are seared to prevent fraying.

Anchor Sling

Model # AS-2-6: Six (6) ft anchor slings are made of 1-3/4" wide nylon webbing with a 3" wear pad to protect against abrasion. This type of sling is designed to provide inertia-complying anchorage. When attached to proper support member, it is capable of holding at least 5,000 lbs. It is a choker type sling and has one small D-Ring that passes through a larger D-Ring. Connection is made to the smaller D-Ring.

Carabiners

Model # 5105: Automatic lock, alloy steel, Min. breaking strength 5,000 lb. Gate opening 3/4"

Storage Bag

Model # CB2: 12" x 12" x 20" Cordura

NOTE: A worker must wear an approved full-body Harness with a D-ring at the center of the back or above shoulder level. The lanyard that attaches to the D-ring must be no more than 6 feet. Lanyard shall be kept as short as possible to minimize the free fall distance but within the parameters set forth in these instructions. Free fall distance shall not exceed 4 feet. The snaphook should be attached to the O-ring on the lifeline. All products must meet OSHA and ANSI requirements.

ANCHORAGE POINTS

As per OSHA requirements; Anchorages shall be capable of supporting at least 5,000 pounds per employee attached, or shall be designed, installed, and used as part of a complete personal fall arrest system which maintains a safety factor of at least two and under the supervision of a qualified person.

INSTALLATION

Only trained and competent personnel, who have read and who understand all instructions, should Install the Horizontal Rope Lifeline System. All parts of the system must be made or approved by Gemtor, Inc. Substitution or replacement with non-approved components will endanger the integrity of the system and may effect the reliability and safety of the total System. Precautions should always be taken to remove any obstructions, debris, and other material from the work area that could cause injuries or interfere with the operation of the system. Caution should always be taken to insure that all equipment will be clear of recognized hazards before work begins. The HL1-60 System must be installed between anchorage points that are at the same level and positioned from waist-height to above the head-height of the user. **Never below waist level** (See Hmin requirements on page 6 & 10.) The anchorage point must be stable, horizontally in line with lifeline and independent of the work surface. When the lifeline is at or above the user's head, rather than at waist height, the falling distance and potential impact force are reduced.

INSTALLATION *(cont.)*

The HL1-60 lifeline system (Fig. 2) must be installed at a minimum height above the walking/working surface (Hmin) to limit maximum free fall distance. The system may only be used where there is sufficient minimum clearance (MC) to prevent a worker from striking the next lower level (surface toward which a worker might fall). This height is equal to the lifeline deflection, plus lanyard length and any elongation, plus the height of the worker, plus a 2 ft. safety margin.

When two workers work within the same segment of a horizontal lifeline system extra precautions must be taken to ensure that the second worker is not pulled from his work location and subjected to a free fall of more than 6 ft. if the first worker falls. The only way to prevent a second worker from being pulled from his work area and ensure OSHA compliance is to use the appropriate length lanyard (see chart below) and to install the horizontal lifeline system at a minimum height that is appropriate for the length of lanyard being used. When two workers are on the same segment of horizontal lifeline, only a 5 ft. or 6 ft. long lanyard should be used and the lifeline must be installed to the specifications in the chart below. Remember, OSHA requires the following: "Horizontal lifelines shall be designed, installed and used under the supervision of a qualified person, as part of a complete personal fall arrest system, which maintains a safety factor of at least two."

Minimum Clearance Calculation:

- A → 6.5 ft.(lifeline deflection) *use chart below*
- B → 5 ft.(lanyard length)
- W → 6 ft.(worker height)
- 2 ft. (safety margin)
- MC → 19.5 ft.(Minimum Clearance)

Minimum Installation Height (Hmin) Calculation:

One Worker

Lanyard Length + 1 ft. = Hmin

Two Workers

Use Only 5 ft. or 6 ft. long lanyard.

5 ft. lanyard → Hmin = 7.5 ft.

6 ft. lanyard → Hmin = 7 ft.

WARNING

The Model # HL1-60 Horizontal Lifeline must be installed to these specifications (*Hmin* Requirements).

One Worker

Lifeline Span	Deflection (A)	Lanyard* Length (B)	Height Of Worker (W)	Safety Margin	Minimum Clearance (MC)	Minimum Installation Height (Hmin)
30 ft.	6.5 ft.	3 ft.	6 ft.	2 ft.	17.5	4 ft.
30 ft.	6.5 ft.	4 ft.	6 ft.	2 ft.	18.5	5 ft.
30 ft.	6.5 ft.	5 ft.	6 ft.	2 ft.	19.5	6 ft.
30 - 60 ft.	7.5 ft.	3 ft.	6 ft.	2 ft.	18.5	4 ft.
30 - 60 ft.	7.5 ft.	4 ft.	6 ft.	2 ft.	19.5	5 ft.
30 - 60 ft.	7.5 ft.	5 ft.	6 ft.	2 ft.	20.5	6 ft.

Two Workers

Lifeline Span	Deflection (A)	Lanyard Length (B)	Height Of Worker (W)	Safety Margin	Minimum Clearance (MC)	Minimum Installation Height (Hmin)
30 ft.	8.5 ft.	5 ft.	6 ft.	2 ft.	21.5	7.5 ft.
30 ft.	8.5 ft.	6 ft.	6 ft.	2 ft.	22.5	7 ft.
30 - 60 ft.	11 ft.	5 ft.	6 ft.	2 ft.	24	7.5 ft.
30 - 60 ft.	11 ft.	6 ft.	6 ft.	2 ft.	25	7 ft.

Note: Minimum Clearance (MC) and Minimum Installation Height (Hmin) must be adjusted based on actual workers height and must be based on the tallest worker. *The horizontal lifeline system is designed for use with a standard rope or web lanyard, an energy absorbing lanyard will increase required minimum clearance by up 42" and therefore is not recommended.

INSTALLATION *(cont.)*

⚠ WARNING

If the required lifeline span exceeds 60 ft., then intermediate supports must be used at intervals of no more than 60 ft. and no more than two workers may work within a segment (between supports) of lifeline.* If intermediate supports are not used, lifeline deflection will increase greatly, and the system may be unpredictable and dangerous. Intermediate supports must be capable of supporting at least 5000 lbs. When intermediate supports are used, the lifeline must remain level and straight from end point to end point and as it passes through the intermediate supports. Overall lifeline length should not exceed 300 ft. Keep in mind that reducing the span between anchorages or intermediate supports reduces lifeline deflection and required minimum clearance. This is especially important if more than one worker ties-off within the same lifeline span.

Assembling the system

The HL1 system usually comes to the customer fully assembled. If this is not the case, the customer can assemble the lifeline by the following steps:

- 1) Thread the free end of the lifeline through the Unitensioner[®] and rope grab, as shown in fig. 3.
- 2) Tie a knot in the free end of the lifeline to prevent it from becoming detached from the Unitensioner[®] during the use.
- 3) Attach the carabiner to the Unitensioner[®] using the swivel eye.
- 4) Attach second carabiner to the thimble at the end of the lifeline.
- 5) Wrap an anchor sling around the anchorage at each end and connect each of the carabiners to the smaller D-ring on the anchor slings.
- 6) Remove slack from lifeline by pulling the rope through the safety ring.
- 7) Use the lever (6) to turn the ratchet in the direction of the arrow until the lever slips. The Unitensioner[®] is adjusted to automatically tension the horizontal lifeline to no more than 300 lbs.
- 8) After the lifeline has been properly tightened, remove the lever.
- 9) Adjust the size of the compensation loop as per the diagram below.

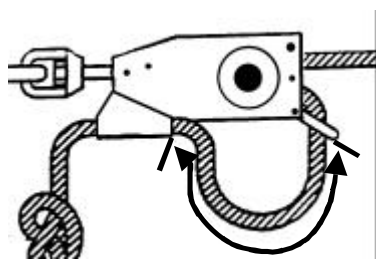

Must be 70 inches long

Note: The compensation loop is critical to the proper operation of this horizontal lifeline system.

FIGURE 1

*** ⚠ WARNING**

When two workers must be tied-off to work in the same area, we highly recommend that each worker is attached to a separate lifeline or, within a separate segment (between intermediate supports) of a lifeline. If this is impossible, then two workers may work within the same segment of the horizontal lifeline only if the lifeline is rigged in such a way so that the fall of one worker does not adversely affect the other workers attached to the lifeline.

HOW THE UNITENSIONER[®] WORKS

In the event of a fall, the sudden increase in force on the lifeline will pull the rope which will cause rotation of the pulley and shock absorber mechanism (fig. 4, "B") since they are both fixed on the axle. The mechanism (fig. 4, "B") will absorb the energy of the fall. The length of the pulled out rope comes from the compensation loop that is located between the pulley and the rope grab. When the system stops, the worker will be suspended by the lifeline. After rescue operation, the lifeline must be withdrawn from service and sent to Gemtor Inc., for inspection of the system and rope replacement. In addition to the shock mechanism, there is a rope grab that prevents the lifeline from being freely drawn from housing of the Unitensioner[®]. In order to absorb the falling worker's energy, the rope must have a compensation loop between the rope grab and the pulley (fig. 1 & 3). The action significantly reduces the impact force on the anchor points and the force applied to the worker.

REMOVAL/UNFASTENING

Before taking down the HL1, the worker needs to unlock his lanyard from the horizontal lifeline and hook it to the supporting structure. Install the lever (fig. 4, "6") and, with one hand, slightly turn in the tightening direction. While maintaining pressure on the lever, push on the orange button with the second hand and slowly turn the lever in the opposite direction. This action will disengage the shock absorber mechanism and create slack in the lifeline, allowing the carabiners to be detached from anchor points (anchor slings).

TRAINING:

The employer shall provide a training program for each employee who might be exposed to fall hazards. The program shall enable each employee to recognize the hazards of falling and shall train each employee in the procedures to be followed in order to minimize these hazards.[OSHA 1926.503(a)(1)]

The employer shall assure that each employee has been trained, as necessary, by a competent person qualified in the following areas:

- (i) The nature of fall hazards in the work area;
- (ii) The correct procedures for erecting, maintaining, disassembling, and inspecting the fall protection systems to be used;
- (iii) The use and operation of guardrail systems, personal fall arrest systems, safety net systems, warning line systems, safety monitoring systems, controlled access zones, and other protection to be used;
- (iv) The role of each employee in the safety monitoring system when this system is used;
- (v) The limitations on the use of mechanical equipment during the performance of roofing work on low-sloped roofs;
- (vi) The correct procedures for the handling and storage of equipment and materials and the erection of overhead protection; and
- (vii) The role of employees in fall protection plans;
- (viii) The standards contained in this subpart.[OSHA1926.503(a)(2)]

The employer shall verify compliance with paragraph (a) of this section by preparing a written certification record. The written certification record shall contain the name or other identity of the employee trained, the date(s) of the training, and the signature of the person who conducted the training or the signature of the employer. If the employer relies on training conducted by another employer or completed prior to the effective date of this section, the certification record shall indicate the date the employer determined the prior training was adequate rather than the date of actual training.[OSHA 1926.503(b)(1)]

INSPECTION:

Before each use, visually inspect for physical damages, wear and corrosion on the HL1 component parts. Check the Unitensioner[®] for damage, cracks, wear, corrosion, or malfunctioning parts. Inspect the lifeline for cuts, frays, burns, or broken fibers. Inspect webbing slings or cable slings for cuts, frays, or burns. Inspect each system component in accordance with its associated operation and instructions manual. If the inspection reveals a problem or an ineffective condition, remove the unit from the service.

SERVICING

Servicing must be carried out by a qualified person trained in the inspection and replacement of the system. A record log of all servicing and inspection dates of the system should be maintained by the company's safety officer. The system and all components must be withdrawn from service if subjected to fall arresting force. Only original Gemtor Inc. equipment replacement parts are approved for use in this product. Contact Gemtor Inc. Customer Service Department at Tel # 732-583-6200 Fax # 732-290-9391 if you have any questions.

STORAGE

Clean the components to remove any dirt, cement, paint or other materials that may have accumulated. Store in the included carrying bag, in a dry area when not in use.

TEST RESULTS

	Spans up to 30'		Spans up to 60'	
	One Man (220 lbs.)	Two Men (440 lbs.)	One Man (220 lbs.)	Two Men (440 lbs.)
Lifeline Material	High strength polypro	High strength polypro	High strength polypro	High strength polypro
Lifeline Diameter	5/8"	5/8"	5/8"	5/8"
Free Fall	4'	4'	4'	4'
Compensation Loop	70	70	70	70
Initial Tension	300 lbs.	300 lbs.	300 lbs.	300 lbs.
Anchorage Force	1250 lbs.	1300 lbs.	1300 lbs.	1300 lbs.
Lifeline Deflection	6.5'	8.5'	7.5'	11.5'
Maximum Arresting Force**	550 lbs.	700 lbs.	375 lbs.	480 lbs.

* Minimum installation height (*Hmin*) of the horizontal lifeline and lanyard length must be selected based on specifications on pages 6-7, Regardless of the installation height (*Hmin*), Free fall distance must not exceed 4' (see fig. 2).

** Calculated

WARNINGS AND LIMITATIONS

Proper precautions should always be taken to remove any obstructions, debris, and other materials from the work area that could cause injuries or interfere with the operation of the system. Caution should always be taken to insure that all equipment is clear of recognized hazards before work begins.

NOTE: Users should be familiar with pertinent regulations governing this equipment. All individuals who use this product must be correctly instructed on how to use this system, and must read and understand the following instructions before use:

- Only trained and competent personnel should install and use this system and its components.
- Do not exceed the work lengths listed above.
- Use Gemtor supplied High strength polypro rope lifeline only.
- Do not use the system if the Unitensioner[®] does not lock onto the lifeline or if any component in the system does not operate properly or appears to be damaged.

Equipment must be inspected before each use; if bent, damaged or if parts have been substituted **DO NOT USE**. Return to Gemtor for reconditioning or repair.

IMPORTANT: This device should be returned to our facilities on an annual basis for physical inspection and re-certification or whenever damaged or subjected to fall arrest forces (impact loaded). Only original Gemtor replacement parts are approved for use in this device.

IF YOU HAVE ANY QUESTIONS CONCERNING THE CORRECT USAGE OF THIS OR ANY GEMTOR PRODUCT, DO NOT USE, CALL (TOLL FREE) 1-800-405-9048

Do not try to adjust, repair or modify any Gemtor equipment; for prompt service, please contact: Gemtor, Inc., One Johnson Avenue, Matawan, NJ 07747, Tel. 732-583-6200

FIGURES

SPAN

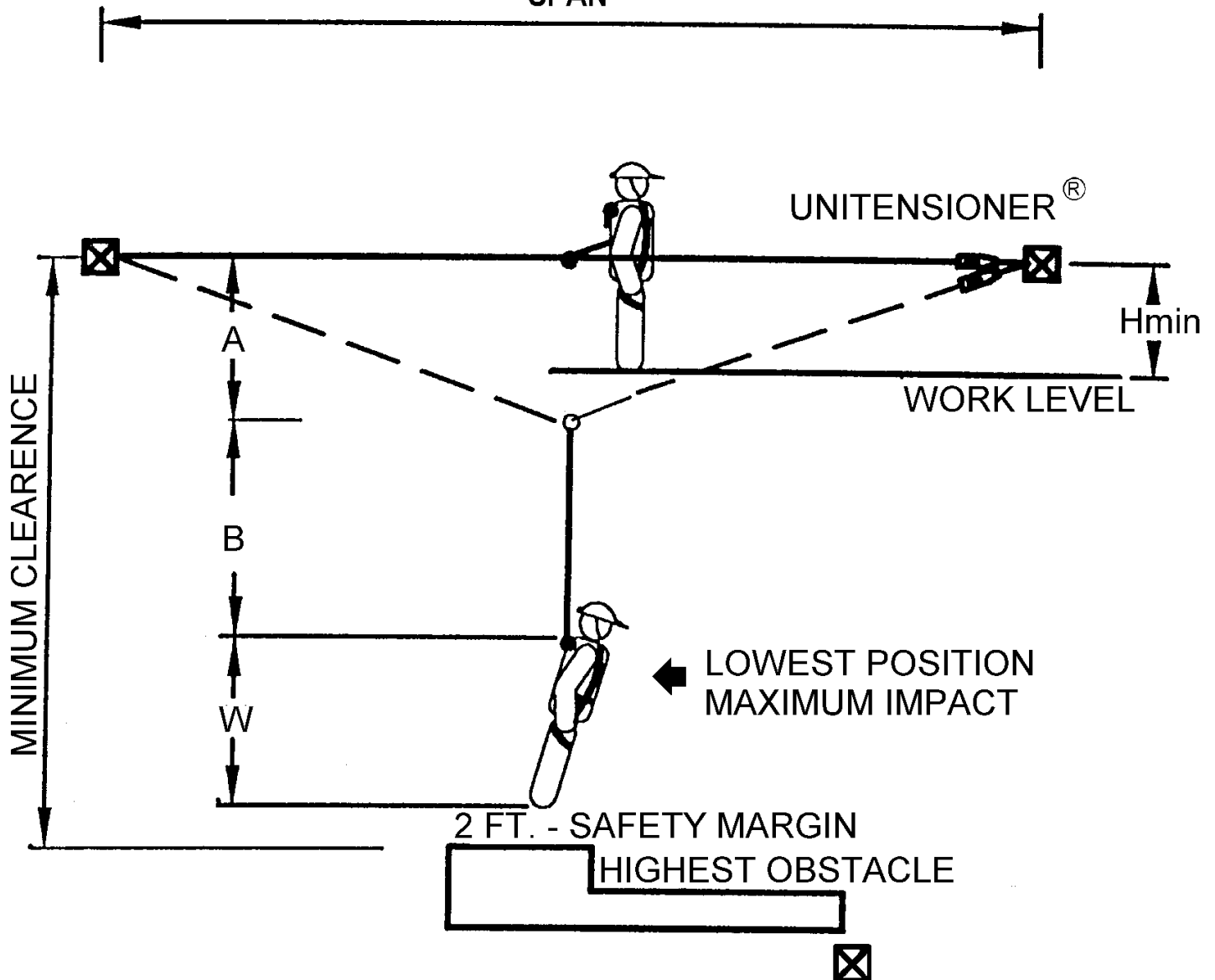

Minimum Clearance calculation

A – LIFELINE DEFLECTION

B – LANYARD LENGTH

W – WORKER'S HEIGHT

2 FT. SAFETY MARGIN

MC – MINIMUM CLEARENCE

Hmin		
Lanyard length	One Worker	Two Workers
3 ft.	4 ft.	N/A
4 ft.	5 ft.	N/A
5 ft.	6 ft.	7.5 ft.
6 ft.	7 ft.	8 ft.

Figure 2

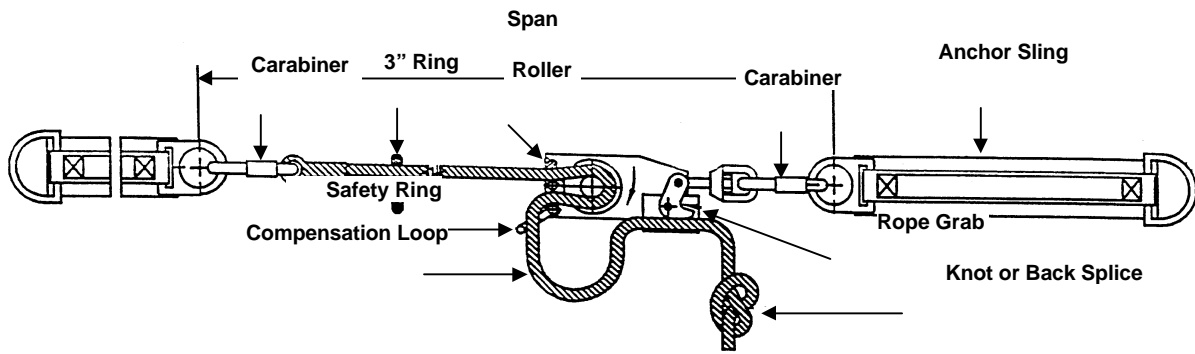

Figure 3

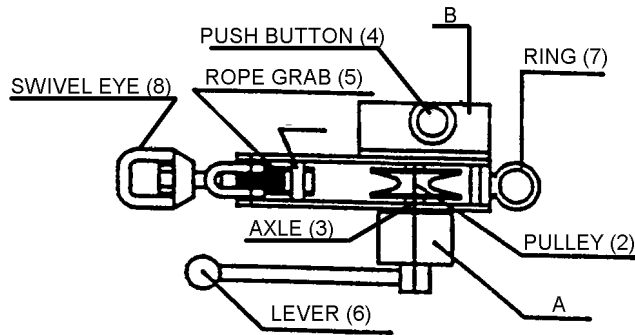
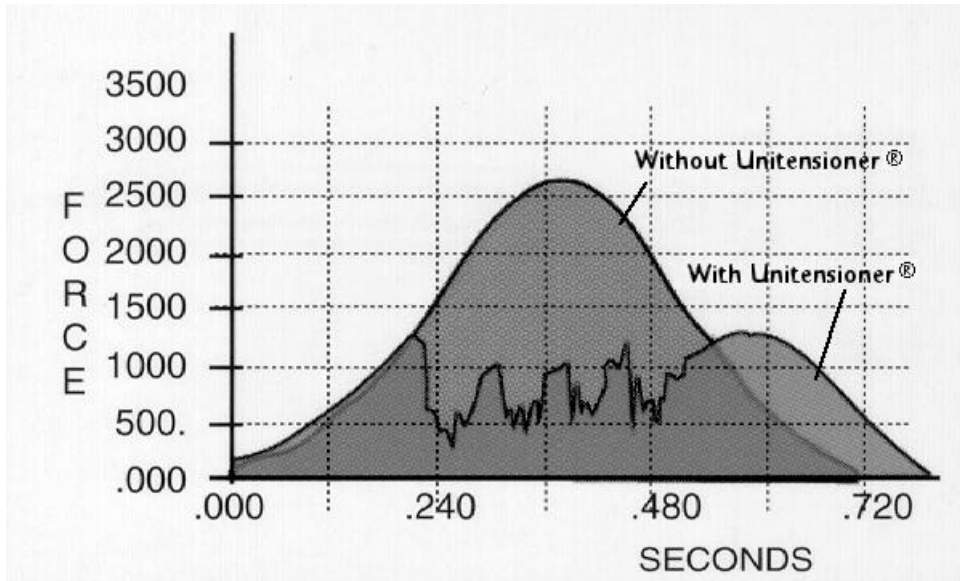

Figure 4
Figure 5



GEMTOR, INC.
One Johnson Avenue
Matawan, NJ 07747
732-583-6200

